

356 Capri Blvd. Naples, FL 34113

Phone Number: **Read Troubleshooting Section First!**

Email: info@gemremotes.com WWW.GEMREMOTES.COM

**Warning, DON'T CONNECT WIRES COLOR TO COLOR INSIDE THE MOTOR
Read All Directions Prior To Installation!**

EACH USER MUST READ THE INSTRUCTIONS ON THE YELLOW FACE CARD INSIDE THE GEM UNIT ON THE DOCK!

Use of other wiring directions could result in damage to your GEM unit and/or the motors!

Not following the directions could cost you time and money!!

To ensure proper installation of your GEM Controller, use GEM's directions in lieu of all others.

GEM Remotes units are not designed to be used in conjunction with hand or drum switches. If drum switches worked with your motors and you must remove them, you must check inside the motor to ensure proper connections to the GEM unit. Overload protection is not provided. Do not use oversized circuit protection use chart below. Use type 3 conduit hubs Only. **Caution:** Bonding (grounding) between conduit is not automatic, it must be provided upon installation. The **GEM unit is wired for 115VAC or 230VAC** (3 wires + ground). No modifications to the GEM transformer are needed. GEM recommends that all 2 motor systems or excessively long electrical runs be wired at 230VAC. If wired at 230VAC then all motors must be re-configured internally for 230VAC. Motors come from the factory wired at 115VAC or 230VAC. See the next page for confirmation of motor wire configuration. The transformer is wired to the White wire (neutral 115VAC). If you don't have a neutral you will have to rewire the transformer for 230 only. If you have a GEM GFI you need a neutral(do not tie motor white wire to incoming power it need to go to GEM White wires) if you don't have a neutral and wiring at 230VAC then you will need a non GEM GFI unit. Read label inputs and outputs on the transformer for proper wire connections. Gem motor feed white wire is not used for 230VAC connection to the motor unless 115VAC brake is used. Green or bare wires must only be used as a ground. **It is unsafe to use a ground as a neutral.** Please use the chart below for proper wire size. If you use the wrong size wire you could damage your motors and/or the GEM unit. If you get a grinding sound in the contactor during use then you have a voltage drop greater than 5%. We have **23** years of experience. We recommend that you read and use the Step by Step Wiring Procedures before starting the installation. It could save you time and money.

Use this chart to size wire and circuit protection. Measure the distance between the main breaker and the motors.

Recommended Wire Size for Installation of your GEM Controller-1 Phase,75C Copper Wire

# of Motors	Motor HP	115 Volt AC Main Feed							230 Volt AC Main Feed						
		Amps to run	Breaker Size	50 Feet	100 Feet	200 Feet	300 Feet	400 Feet	Amps to run	Breaker Size	50 Feet	100 Feet	200 Feet	300 Feet	400 Feet
1	1/2	8.8	10 Amps	12	10	6	4	4	4.4	5 Amps	14	14	12	10	10
1	3/4	10.8	15	12	8	6	4	3	5.4	10	14	14	12	12	10
1	1	12.8	15	10	8	6	4	3	6.4	10	14	14	12	12	10
1	1 1/2	17.0	20	10	6	4	2	1	8.5	10	14	14	10	10	8
2	1/2	17.6	20	10	6	4	2	1	8.8	10	12	12	10	8	6
2	3/4	21.6	25	8	6	3	1	----	10.8	15	12	12	10	8	6
2	1	25.6	30	8	4	2	1	----	12.8	15	12	10	8	6	4
2	1 1/2	34.0	35	6	4	1	2/0	----	17.0	20	12	10	8	4	2
4	1/2	----	----	----	----	----	----	----	17.6	20	12	10	6	4	4
4	3/4	----	----	----	----	----	----	----	21.3	25	12	8	6	4	3
4	1	----	----	----	----	----	----	----	26.0	30	10	8	4	3	2
4	1 1/2	----	----	----	----	----	----	----	36	35	10	6	4	2	1
4	2	----	----	----	----	----	----	----	44.8	45	8	6	3	1	1/0

Breakers size is our recommendation. Please use motor label for proper size and code compliance.

Step by Step Wiring Procedures

- Open the GEM box, remove the face card screws (be careful of the tail on face card) and remove the motor inspection cover.
- For shipping purposes in the Gr4 remove black cord "pull this out" it is placed into the down contactor pull it out.** Strip main feed and motor wires inside the GEM unit.
- Hook up your unit at 230VAC if possible (see figure 1A) or 115VAC wiring use figure 1B. The **GEM main feed White and GEM Red wires** should be connected together with the white main feed wire. (Neutral = 115VAC between White and Black wires. Make sure that this is the case.) If your unit is a 4 motor or a special order 230VAC you will not have a neutral.
- Turn off power at the circuit breaker.** Use properly sized circuit breaker and wire size. See wire chart on page 1.
- Cut off the drum switches. Drum switches can not be used in conjunction with the GEM unit.
- Connect wires color to color inside the GEM box (or inside a junction box) using wire nuts. (Not color to color inside the motor!)
- Wiring the motors and the GEM unit at 230VAC: Cap off the GEM White motor wires. These wires are not used at 230VAC.
- To confirm and/or change motor wiring, open motor covers and configure motor winding wires as shown below. **Inspect wires inside each motor to ensure proper wire connection.** Use the motor wire diagrams below. Failure to do so could damage your motors. **You may have to move wires inside the motor even though the drum switches worked.** To reverse motor starting direction, swap wires **inside motor!** Some motors have circuit protection and output wires from these might have different color wires. Also, some motor manufacturers prewire their motors with wires that don't have 5 matching wires to the GEM unit. You must check inside each motor to insure proper wiring. Some use blue and/or yellow wires as a substitute for green ground or orange wires. To help you find your motor chart if you have terminals inside the motor check for that motor diagram otherwise use the Standard T Numbered Wire motor chart or the Standard color motor wire chart below.
- If your unit is an Auto-Stop unit read those directions. Your unit will not work without the limit switch wires hooked up properly. **Check that your lift stops in both the up and the down direction! An Auto-Stop unit must be hooked up to a GEM limit switch. Failure to do so could result in damage to your lift and/or the boat and is against code and not insured.**
- Turn off unit when not in use. Read operating instructions printed on the yellow face card, inside the GEM box.**
- Test the GFI** (if equipped) once every month and or before each use. GEM's GFI Needs a Neutral(115) to work.
- If you have 2 motors and you need to level the lift, hold the level switch in the off position. While holding it down raise or lower the Motor #1 using the manual switch. **Do not let go of the level switch until Motor #1 is level and is stopped.**
- The new 2007 unit has a 3 second delay before switching directions this is to ensure that the motors turn the correct direction.
- Attach the new face card electronic tail to the receiver board, replace the screw.
- A replacement transmitter or a spare can be bought online, loss of range or unit hiccup check battery, 2: 3volt, Cr2032.

Main Feed Wire Connections

230VAC WIRING Figure 1A

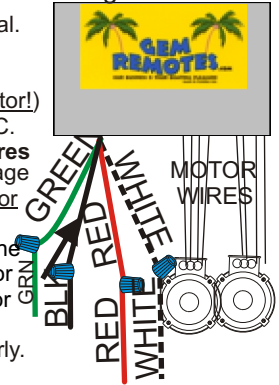

Main Feed Wire Connections

115 VAC WIRING Figure 1B

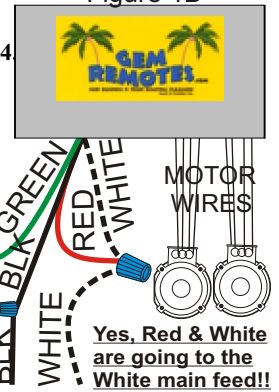

Run Light or Brake Connections

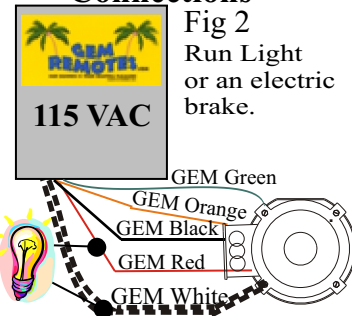

Attach the run light onto the GEM Red & GEM White for 115VAC or 230VAC system that has 115VAC neutral.

To run a 115VAC brake attach wires to GEM Orange and GEM Black when main feed is at 115VAC. If 230VAC brake is used, use GEM Orange and GEM Black. If you have 230VAC system and you only have a 115VAC brake then you must use GEM White & GEM Red. (The GEM white wire will be used at 230VAC).

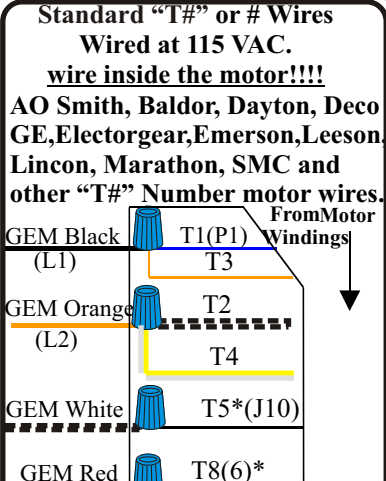

*To change motor direction, switch T5 & T8 motor wires.

To change from 115 to 230VAC:

- Cap GEM White wire (not used).
- Attach 3 motor wires together T3, T5* and T2.
- FYI: GEM Blk to T1(P1), GEM Org to T4, GEM Red to T8(6)*.

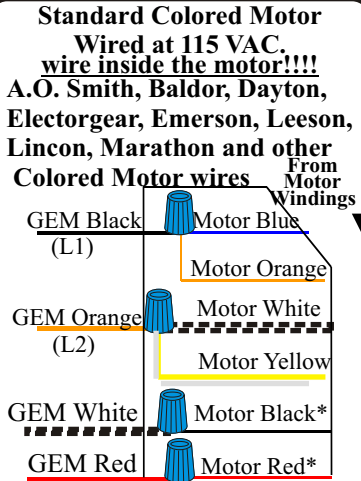
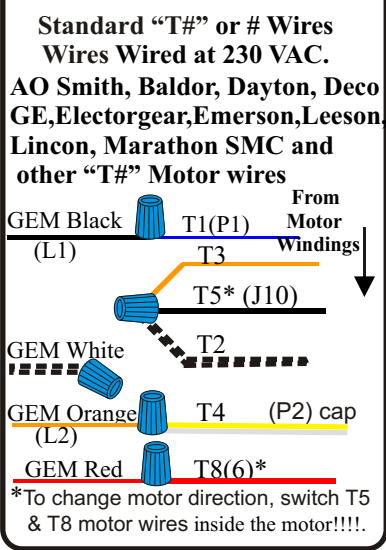

*To change motor direction, switch Motor Red and Motor Black wires.

To change from 115 to 230VAC:

- Cap GEM White wire (not used).
- Attach 3 motor wires together M Org, M Blk* and M White.
- FYI: GEM Black to Motor Blue, GEM Orange to Motor Yellow, GEM Red to Motor Red*.

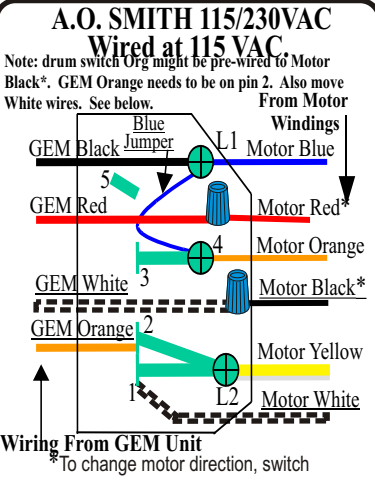
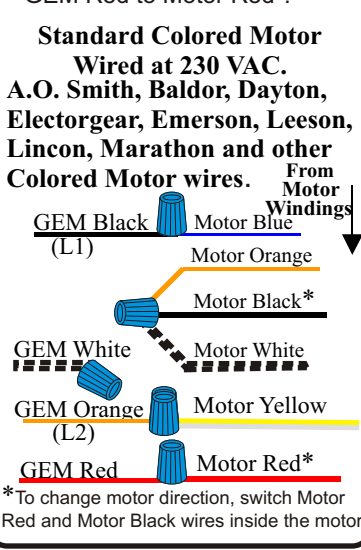

Wiring From GEM Unit

*To change motor direction, switch Motor Black & Motor Red wires

To change from 115 to 230VAC:

- Cap GEM White wire (not used).
- Place Motor Black on pin 4.
- Move Motor Blue jumper from pin 4 to pin 5.
- GEM Orange is on pin 2!!!!!!**
- Move Motor White from pin 1 to 3.

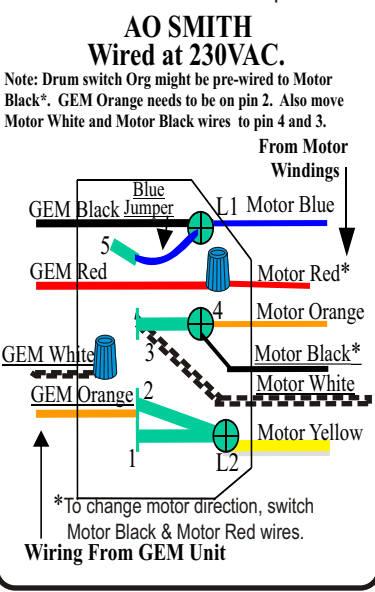

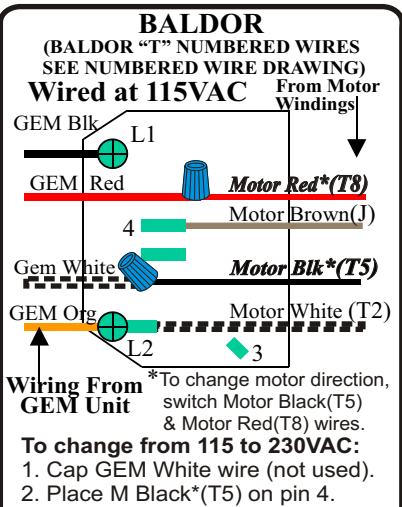

Wiring From GEM Unit

*To change motor direction, switch Motor Black(T5) & Motor Red(T8) wires.

To change from 115 to 230VAC:

1. Cap GEM White wire (not used).
2. Place M Blk*(T5) on pin 4.
3. Move M Brn(J) from pin 4 to pin 3.
4. Move M WHT(T2) from L2 to pin 4.

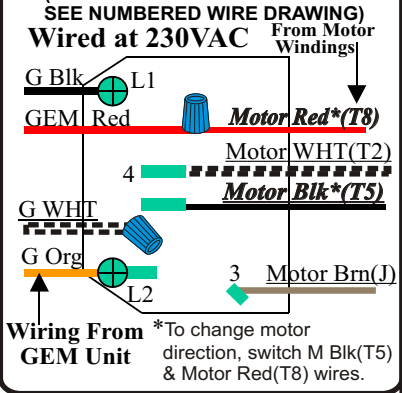

Wiring From GEM Unit

*To change motor direction, switch M Blk(T5) & Motor Red(T8) wires.

To change from 115vac to 230:

1. Cap GEM White wire (not used).
2. Move Motor Orange from pin 1 to pin 5.
3. Move Motor White from 6 to pin 5.
4. FYI: GEM Black and Motor Blue on 1, GEM Orange and Motor Yellow on 6.

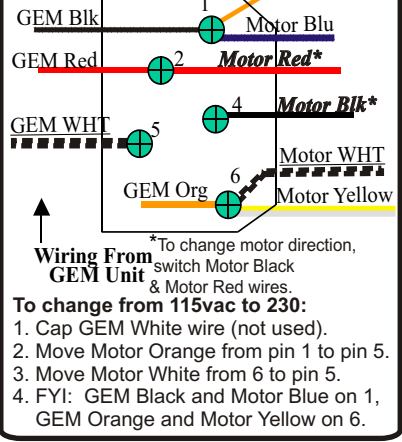

Wiring From GEM Unit

*To change motor direction, switch Motor Black & Motor Red wires.

To change from 115vac to 230:

1. Cap GEM White wire (not used).
2. Move Motor Orange from pin 1 to pin 5.
3. Move Motor White from 6 to pin 5.
4. FYI: GEM Black and Motor Blue on 1, GEM Orange and Motor Yellow on 6.

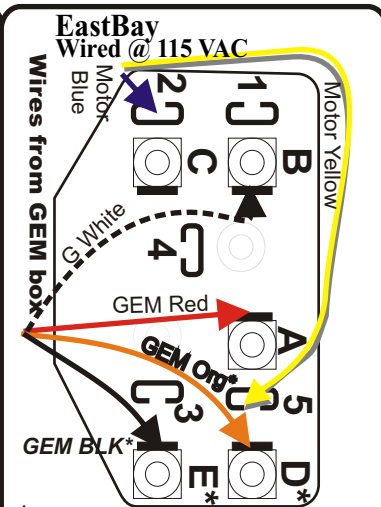

Wires from GEM box

*To change motor direction, switch wires on D&E(GEM Org & GEM Black)

To change from 115vac to 230:

1. Cap GEM White wire (not used).
2. Move Motor Blue from 2 to 3.
3. Move Motor Yellow from 5 to 4.
4. Move GEM Org from D* to C.
5. Move GEM Blk from E* to A.
6. Move GEM Red from A to E*.
7. Make a Jumper wire and place on pin B and Pin D*.

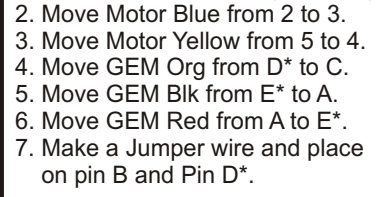

Wiring From GEM Unit

*To change motor direction, reverse wires on D & E (Jumper wire & red).

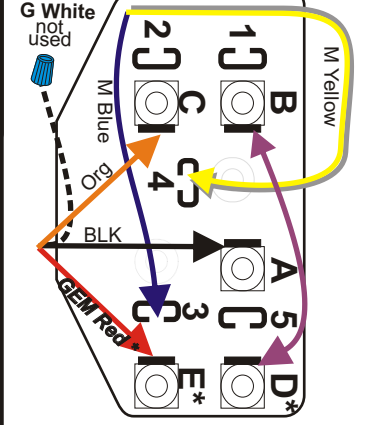

Wiring From GEM Unit

*To change motor direction, switch Motor Black & Motor Red wires!

To change from 115vac to 230:

1. Cap GEM White wire (not used).
2. Move Motor Orange from pin 1 to pin 5.
3. Move Motor White from 6 to pin 5.
4. FYI: GEM Black and Motor Blue on 1, GEM Orange and Motor Yellow on 6.

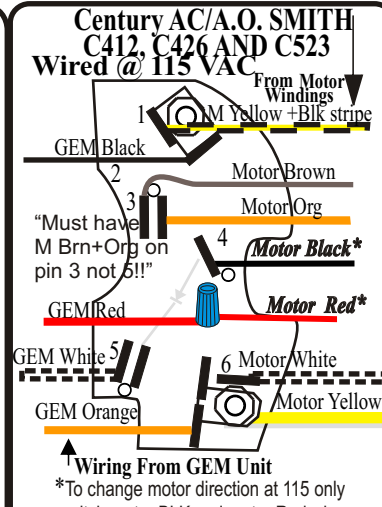

Wiring From GEM Unit

*To change motor direction at 115 only switch motor Blk and motor Red wires.

To change from 115vac to 230:

1. Cap GEM White wire (not used).
2. Move Motor Org from 3 to 5.
3. Attach M Whit & M Red* on pin 5.
4. FYI: GEM Org & M Yellow on 6.

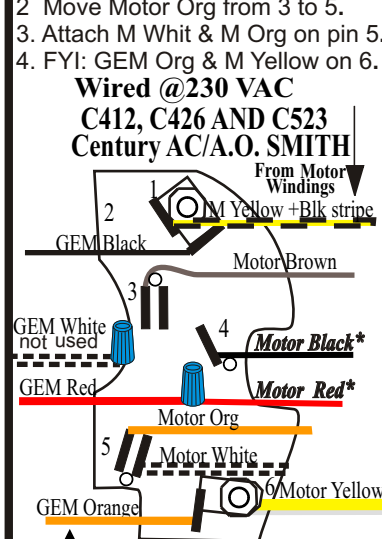

Wiring From GEM Unit

*To change motor direction, switch Motor Black! & Motor Red wires!



Wiring From GEM Unit

*To change motor direction, switch Motor Red! & Motor Yellow wires!

To change from 115vac to 230:

1. Cap GEM White wire (not used).
2. Move Motor Yel with Motor WHT & Org.
3. FYI: GEM Blk to M Blk, GEM R to M R, GEM Org to M Blue.

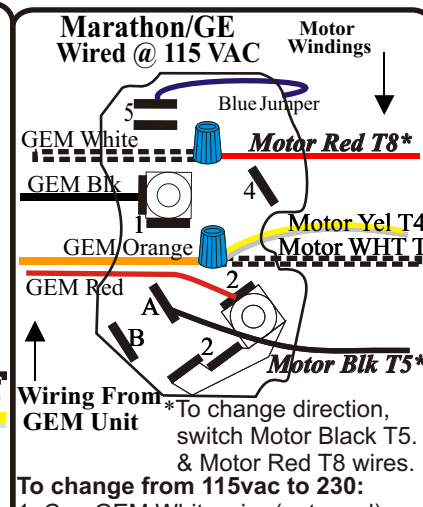

Wiring From GEM Unit

*To change direction, switch Motor Black T5. & Motor Red T8 wires.

To change from 115vac to 230:

1. Cap GEM White wire (not used).
2. Move Blue Jumper from 5 to 4.
3. Attach MWht & MRed*(T8) on pin 5.
4. FYI: GEM Org & M Yellow together.

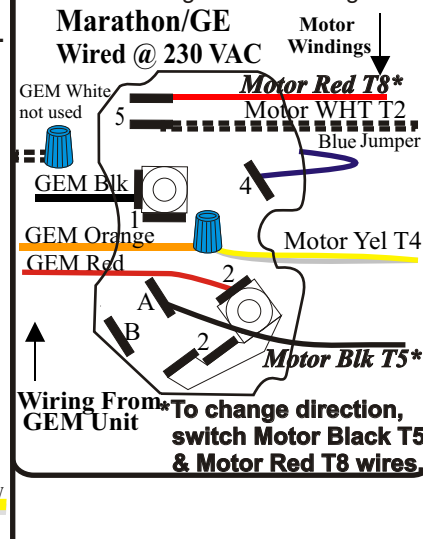

Wiring From GEM Unit

*To change direction, switch Motor Black T5. & Motor Red T8 wires.

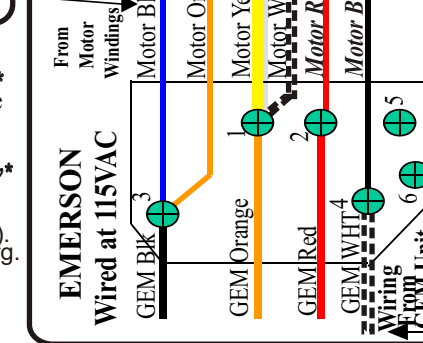

Wiring From GEM Unit

*To change motor direction, switch Motor Blk and Motor Red wires.

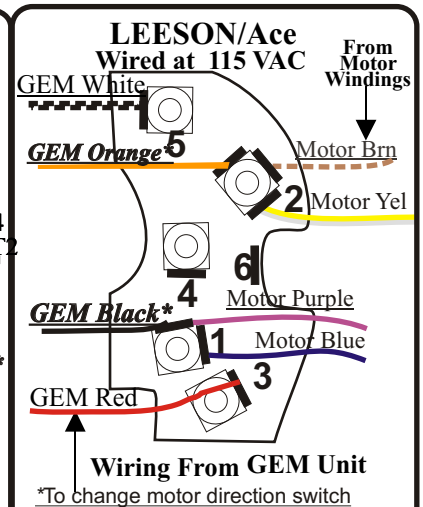

Wiring From GEM Unit

*To change motor direction switch GEM Org & GEM Blk wires

To change from 115vac to 230:

1. Move GEM White from pin 5 to 6.
2. Move motor Purple wire from 1 to 5
3. Move motor Brown wire from 2 to 5
4. *To change direction of the motor switch GEM Org & GEM Black wires.

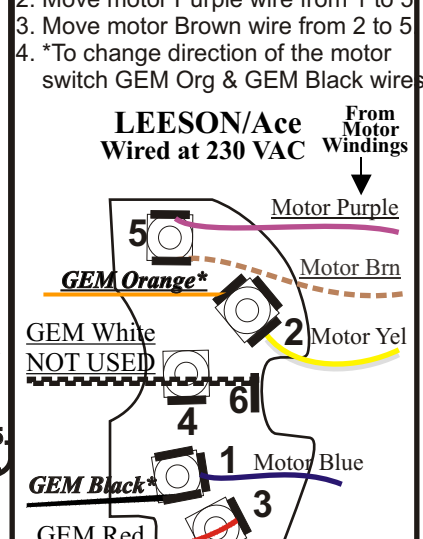

Wiring From GEM Unit

*To change motor direction switch GEM Org & GEM Blk wires

To change from 115vac to 230:

1. Cap GEM White wire.
2. Attach 3 m wires on 4 M WHT, M Blk* & M Org
3. FYI: GEM Blk & Motor Blue on 3, GEM Org & Motor Yellow on 1 GEM Red & Motor Red* on 2.

to a GEM GR2A. **GEM ORANGE WIRE IS ON PIN 2**

See previous pages for more motor wire diagrams.

**MAIN FEED
POWER 230VAC
(3wires+ground)
Wired to GEM
at 115VAC**

These 4 exploded views are inside the GEM Box

Yes @115V the GEM White and Red go to Neutral

240 Volt hook up using only 3 wires(2+G) Not using Neutral(White) You must rewire the Multitap transformer see #13 below. Can't be done to a GEM GFI (needs 115vac to work).

Only use this diagram when you don't have a neutral, can't be used with GEM's GFI.

TROUBLESHOOTING:

1. If your remote works but your membrane switch buttons don't work you need to plug in the M/S tail to the receiver board.
2. You must **Cut off drum switches**: They worked, but the GEM unit only works in 1 direction; You need to rewire inside motors, Note GEM Org wire.
3. **1 or 2 motors turn in the wrong direction**: Switch **motor wires**, wire inside the motor BLK*(T5) with Red*(T8) see motor diagram pages.
4. **Chatter or grumble in the contactor**: Check for low voltage, when system is running (override by pushing in contactor). Check wire size vs. run length all the way from the motors to the breaker at the house. If the lift has more than 1 motor, the wires size going from the GEM to the motor use the 1 motor chart and use total run length back to the breaker. Example 2 3/4 hp motors 300' = #6 to the motors and #2 to the GEM unit at 115VAC.
5. **Motor not working**: Color to Color wiring inside the motor is incorrect. You must use GEM's motor wire diagrams. **A.O. Smith motors move GEM Orange wire to pin 2** GEM units works with 115/230VAC 1 phase, cap. start, **induction run motors**. Three phase motors require special order. 1 1/2 horsepower motors and larger can have a cap. start and a cap. run. The run cap. might not reverse or the run cap. can explode. It must be removed, this will increase the run amps that the motor will draw by 3 amps(Eastbay motors, 2 cap systems are compatible).
6. A transmitter **does not work** 3 second delay when switching direction, or check that LED on transmitter lights and check learn button LED lights when receiving from the transmitter. Relearn the transmitter, press the learn button 1 time and then push the Stop button the Learn LED should flash.
7. **Short range or lift hiccups**: If the red LED on the transmitter flickers, **replace the batteries 2: 3Volt CR2032**. Do not change the length of the antenna wire. This will not help the range. Metal will hurt the range, you should have line of sight for the unit to have a 300 foot range (2007 units).
8. If the GEM unit does nothing check that the LED Flashes when powered up. If not flashing then check your power you can also press in the middle of bottom contactor if the lift runs, you have main power but your 24 VAC transformer is not working. **Auto-Stop units must be hooked up to a limit switch**. A fast flash on the LED means that the up limit is reached a slow flash is for the down limit. **It is against code and not covered by insurance to be used without a GEM limit switch.**
10. **Clearing the memory**: Press and hold the Learn/Clear button (LED will light) for 7 seconds then the LED will flash stop pressing and all transmitters will be cleared. Then press the learn button the LED will light up, then press the Stop button on the transmitter the Learn LED will flash 2 times.
11. **TROUBLESHOOTING: GFI (GFI and GFI) needs a neutral. 2004 GFI will not reset if it has a fault or is not getting 115VAC.** Disconnect all motor wires, check to see if the GFI resets, then hook up 1 motor at a time to find the fault. Problems are normally far motor.
12. **TROUBLESHOOTING: Wiring at 110VAC-120VAC**: If motors (A.O. Smith) does not work rewire GEM Org inside the motor to pin #2.
 1. 115 VAC motor system problems: **Motor Hum**: Connect **red and white GEM main feed wire together**. See **figure 1A**.
 2. Over sizing the circuit breaker can damage your lift, motors and/or the boat. Use the correct size circuit and wire size. Use wire chart.
13. **TROUBLESHOOTING: Wiring at 220VAC-240VAC**: 4 motor or special order **230V only** do not have a White main feed unless a GFI unit.
 1. **Unless the GEM unit is specifically ordered for 230VAC, a 4 wire main feed is required. If you do not have 3 wires + ground then you will need to rewire the system for 230VAC only (2 wire+Ground)**. Read the label, on top of the transformer BLK-ORG = 240 VAC Cut yellow transformer wire and cap it off. Find ORG wire it should be hiding around the base of the contactor it has a red wire taped to it. Attach the Org wire to the main feed red on the screw. The red wire taped to this wire is used for 208 connections.
14. **TROUBLESHOOTING: Wiring at 208VAC**: Rewire the transformer. Read label BLK-RED = 208 Cut Yellow transformer wire and cap it off. Attach Red to main feed Red.

Need more help? Call 239-642-0873 M-F 8:30-4:00 EST. The web page also has more information for after hours help.

